

multiflex

BUILT TO LAST

MECHANICAL STEERING SYSTEM

MS1-XX

Instruction Manual,
Installation And
Maintenance Guide



CE
ISO 8848



MEMBER
ABYC[®]
Setting Standards for Safer Boating

Dear Customer

It gives us immense pleasure to welcome you to the **multiflex** family.

We appreciate your decision to use **multiflex** products. With over two decades of experience, **multiflex** is one of the leading manufacturers of Steering and Control Products for the boating industry.

multiflex products can be sourced in 80 countries through a wide distribution network.

Our range of products includes -

- ▲ Hydraulic Steering Systems
- ▲ Mechanical Steering Systems
- ▲ Electric Power Steering
- ▲ Engine Control Cables & Control Boxes
- ▲ PWC Cables
- ▲ Steering Wheels
- ▲ Boat Trailer Rollers
- ▲ Mooring Compensators

multiflex Steering Products are tested and conform to :

Recreational Craft and Personal Watercraft Directive 2013/53/EU.

Extensive research, innovation and technology allows us not only to ensure reliability and quality of products but also helps us to increase our product offerings to our customers, including customization of products and services.

Our true endeavor is to present you with the best quality products and excellent services, thus building a strong foundation to our relationship with you.

Warm regards,

Team Multiflex

TABLE OF CONTENTS

A. ABOUT THE MANUAL	01
B. DOCUMENT REVISIONS	02
C. SAFETY SYMBOLS USED	02
D. SAFETY WARNINGS	03
E. NAUTICAL WORD REFERENCE	04
F. WARRANTY	05

SECTION 1 - PRODUCT DESCRIPTION

1.1 FUNCTION OF A MECHANICAL STEERING SYSTEM MS1-XX	07
1.2 TECHNICAL SPECIFICATIONS	07
1.3 PRODUCT DIMENSIONS	08
1.4 PRODUCT EXPLODED VIEW	09

SECTION 2 - PACKAGING CONTENT

2.1 GUIDELINE FOR PRODUCT HANDLING	10
2.2 PACKING LIST	11

SECTION 3 - PRODUCT INSTALLATION

3.1 TOOLS REQUIRED DURING INSTALLATION	12
3.2 INSTALLING MECHANICAL HELM MS1	13
3.3 MOUNTING THE STEERING WHEEL	18
3.4 STEERING CABLE CONNECTION TO THE HELM	19
3.5 VERIFICATION OF STEERING SYSTEM	22

SECTION 4 - TROUBLESHOOTING

4.1 DISASSEMBLING	23
4.2 DISMANTLING STEERING WHEEL	23

SECTION 5 - MAINTENANCE

5.1 MAINTENANCE WARNING	24
5.2 ROUTINE MAINTENANCE	25

A. ABOUT THE MANUAL



- ▲ The Instruction Manual contains all the essential information for the users regarding the purchased Multiflex product. This document is to be given along with the product.
- ▲ ALL RIGHTS ARE RESERVED. Distributing Rights, Part Numbers, Pictures, Text or any content of Multiflex products incorporated in this Instruction Manual property of Multiflex.
- ▲ Use this product only for its intended use as described in this Instruction Manual.
- ▲ This Instruction Manual itself is an important part of the purchased Multiflex product.
- ▲ The Instruction Manual includes - Description of the Products, Safety Warnings and Step wise Procedures for Handling, Assembling, Installation, Maintenance, Disassembling and Replacement of the Products.
- ▲ The user must be aware of the content of this Instruction Manual. No activities regarding the product (like its Assembling, Disassembling, Maintenance, Transport etc.) should be carried out without carefully reading this Instruction Manual.
- ▲ Immense care has been taken in collecting and checking the information contained in this Instruction Manual to make it as accurate and understandable as possible.

Nothing in this Instruction Manual should be understood as a warranty or a guarantee for the products. Nothing contained in this Manual can be interpreted as an amendment or confirmation of the terms of any purchase contract.

Multiflex reserves all the rights to alter the Instruction Manual format if another format is more suitable for the particular product.

Multiflex takes no responsibility for any possible mistakes due to printing errors in this Manual.

NOTE : It is very important to read this Instruction Manual carefully before carrying out any activities involving the product, its handling and unloading.

B. DOCUMENT REVISIONS



REV.	DATE	REVISION DESCRIPTION
1	February-2021	First Edition MS1-XX

C. SAFETY SYMBOLS

The following Symbols / Terms define the various HAZARD identifications in this Instruction Manual to ensure User Safety and to assure correct Installation and Operation of the Product.



DANGER :

The “DANGER” symbol indicates an immediate hazardous situation which, if not avoided, will result in death or serious injury.



WARNING :

The “WARNING” symbol indicates a potentially hazardous situation which, if not avoided, could result in death or serious injury.



CAUTION :

The “CAUTION” symbol indicates attention to unsafe practices which, if not avoided, could result in minor or moderate injury or component damage.



NOTICE :

The “NOTICE” symbol indicates important information for the correct installation and for maintenance that does not cause personal injury or component damage.



SKILLED LABOUR REQUIRED :

The adjacent symbol indicates that all the activities should be carried out by a Professional Marine Technician.

D. SAFETY WARNINGS



It is very important to read this section carefully to avoid any personal harm or injury and also to prevent machinery damage.

Multiflex shall not be responsible for any damage because of the user's negligence.

NOTE : It is advised to read the other manuals as well which are provided with the Steering System Components.

DANGER :

- ✦ DO NOT PUT YOUR HANDS BETWEEN MOVING PARTS.
- ✦ Do not disable the safety devices.
- ✦ Do not use this equipment for a purpose different from the one it has been designed for, which is specified in the Installation and Maintenance Manual.
- ✦ Do not let unskilled staff perform the Installation.

 **WARNING :** DO NOT operate boat if any component is not in proper working condition.

SAFETY RULES :

DURING INSTALLATION :

- ✦ DO NOT modify or substitute any component without written approval from Multiflex.
- ✦ Conform with all system ratings / regulations.
- ✦ Mechanical Steering System must be compatible with the engine / engines installed.
- ✦ There should be **NO** interference between the Mechanical Steering System, Tie-bar and the Transom, Splash-well or Outboard engine or any combination of these parts by performing the following steps.
 - ✦ With Engine fully tilted DOWN, turn Steering Wheel from hard over to hard over and confirm that **NO** interference occurs.
 - ✦ Follow this above step for Engines tilted up.
- ✦ Never use a wire coil type trim switch with a Mechanical Steering System . This may lead to winding up the wire tight around the Steering Wheel shaft which will avert further Steering.

E. NAUTICAL WORD REFERENCE

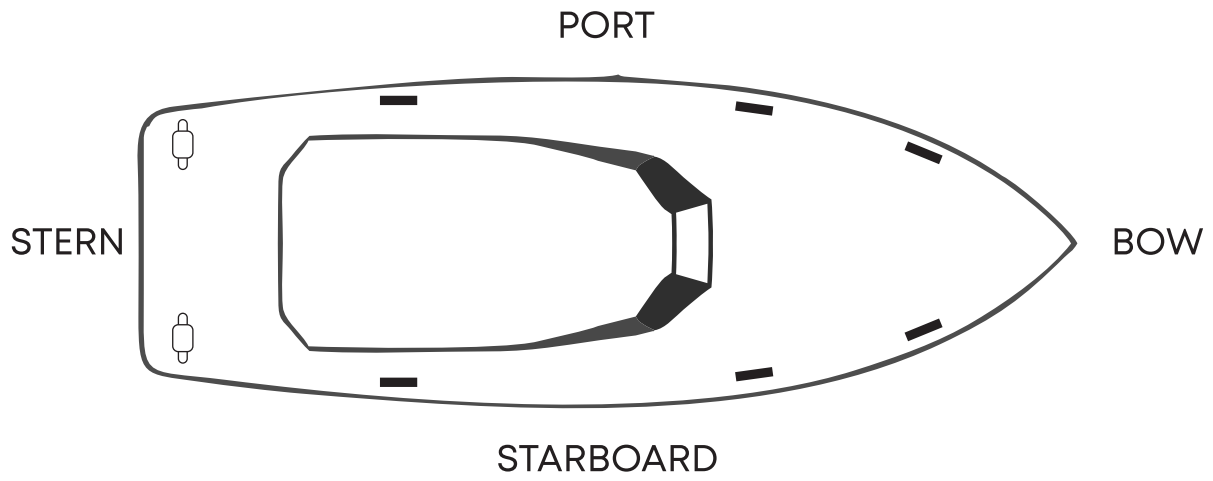

F. WARRANTY



PRODUCT WARRANTY

MULTIFLEX* warrants all products for a period of One (1) year from the date of purchase by the consumer or Two (2) years from the month of manufacture. In both cases, serial number of the product or kit should be shared with Multiflex. Multiflex products are to be free from any defects due to material or manufacturing workmanship. This will be subject to exclusions listed below. Improper installation automatically voids this warranty. Installation is to be performed by a qualified marine technician only. Should the products be altered / disassembled in any manner the warranty shall be void.

If the products are used commercially or in any rental or income generating activity, the warranty shall be:

- ▲ For Mechanical Product: 90 days/3 months from the date of purchase
- ▲ For Hydraulic Product: 180 days/6 months from the date of purchase

(It is mandatory to provide proof of purchase for warranty claim. No claim shall be entertained without the proof of purchase)

EXCLUSION

- ▲ Failure caused by normal wear and tear, climate conditions, miss-use, neglect, lack of proper maintenance, accidents, fire, racing, overloading, modification, beaching or grounding of vessels, collision, impacts, towing, use during war or hostilities, commercial use
- ▲ Components not manufactured by MULTIFLEX
- ▲ Cost of removal, re-installation of any component (including components manufactured by MULTIFLEX) disassembly or reassembly of any parts, units or products containing the component
- ▲ Components not manufactured by MULTIFLEX whether warranted by the other manufacturer
- ▲ Any product that has not been properly and professionally installed
- ▲ Any product that has been installed other than as recommended in our installation or operation instructions or specifications
- ▲ Has been used on boat / engine combination where the engine horsepower exceeds the rating defined by the boat manufacturer
- ▲ Has been used with other products that in the opinion of Multiflex are not compatible

LIMITATIONS

The repair or replacement of any defective parts shall be the PURCHASERS SOLE and EXCLUSIVE Remedy and MULTIFLEX's sole and exclusive liability under this warranty. LABOR FOR ANY REMOVAL, REINSTALLATION OR REPLACEMENT IS NOT INCLUDED. MULTIFLEX's obligation under this warranty is limited to the repair or replacement of product identified by MULTIFLEX as defective, when delivered by the purchaser pursuant to written authorization and instructions from MULTIFLEX. Shipping will be prepaid to MULTIFLEX 's manufacturing facility or any other designated plant or repair facility. Repaired or replaced items are warranted as provided herein for the unexpired portion of the applicable warranty period.

THIS WARRANTY, AND THE RIGHTS AND REMEDIES UNDER IT, IS EXCLUSIVE AND IS GIVEN IN PLACE OF ALL OTHER WARRANTIES, WHETHER EXPRESSED OR IMPLIED. INCLUDING ANY IMPLIED WARRANTY OF MERCHANTABILITY OR FITNESS FOR PARTICULAR PURPOSE, WHETHER ARISING BY LAW, CONDUCT OR USAGE OF TRADE, PURCHASER'S REMEDIES SHALL BE LIMITED AS STATED HEREIN AND MULTIFLEX SHALL NOT BE LIABLE FOR ANY INCIDENTAL, CONSEQUENTIAL OR INDIRECT DAMAGES OR LOSSES RESULTING FROM DEFECTS. ANY ADDITIONAL SELLERS BE IT WHOLESALE OR RETAIL ARE NOT A CO-WARRANTOR AND ARE NOT AUTHORIZED BY MULTIFLEX TO AMEND OR MODIFY THIS LIMITED WARRANTY IN ANY MANNER.

MULTIFLEX employees or associates or representatives oral or any other written statements shall not constitute warranties and should not be relied by the customers and are not part of the warranty stated herein.

WARRANTY MAY NOT BE TRANSFERRED TO SUBSEQUENT PURCHASERS.

MISCELLANEOUS

MULTIFLEX reserves the right to make changes in the design, construction, and manufacturing of its products at any time without notice and without any obligation to incorporate such changes into products of prior manufacture. This limited warranty applies to new components only sold by MULTIFLEX and its group. This limited warranty contains the entire agreements between MULTIFLEX and its group and the purchaser and supersedes all prior agreements, discussions, negotiations, commitments, and representations, whether oral or written, between them regarding MULTIFLEX and its group's warranty.

OUR PRODUCTS ARE NOT INTENDED FOR USE IN RACING APPLICATIONS WHETHER PROFESSIONAL AMATEUR. OUR WARRANTY DOES NOT COVER LABOR, TOWING, OR ANY OTHER ASSOCIATED EXPENSES. FURTHER, IT DOES NOT COVER PRODUCTS THAT HAVE BEEN IMPROPERLY INSTALLED, DAMAGED DURING INSTALLATION, MISAPPLIED, OR MISUSED.

MULTIFLEX shall be THE SOLE ENTITY FOR DETERMINATION OF A DEFECTIVE PRODUCT. DEFECT WILL NOT BE DETERMINED UNTIL SAID PRODUCT HAS BEEN INSPECTED BY MULTIFLEX AND ITS GROUP AT THEIR MANUFACTURING FACILITY SPECIFIED AT TIME OF CLAIM.

Any product that is presumed to be defective should be reported to MULTIFLEX and its group within 48 hours of discovery. Upon notification MULTIFLEX and its group will attempt to troubleshoot the problem with our customer over the phone / email. If we are unable to resolve the problem MULTIFLEX and its group will issue a Returns Material Authorization Code and ask that the product in question be sent back to MULTIFLEX and its group specified facility with all parts and original packaging. All returned products must be returned freight prepaid.

If any part of the Limited Warranty is determined to be void or illegal the remainder shall remain in full force and effect.

If you need to begin the warranty process, please email what your product is, current issue, name and contact number to **technical@multiflexmarine.com**

A team member will review your inquiry and get back to you within 48 hours.

***Multiflex is a brand owned by Excel Controlinkage Pvt. Ltd., India.**

SECTION 1 - PRODUCT DESCRIPTION

1.1 FUNCTION OF A MECHANICAL STEERING SYSTEM MS1-XX

The Multiflex Mechanical System MS1-XX conform to Recreational Craft and Personal Watercraft Directive 2013/53/EU in accordance with EN ISO 8848:1995 / A1:2000.

The Steering System is designed to operate in an ambient temperature ranging between -20°C (4°F) and +60°C (+140°F).

All the components of system are explicitly manufactured considering marine environment.

It offers great durability and safety even in extreme environments.

The Multiflex Mechanical Steering System consists of:

1. Planetary Gear Type Helm : H1

The Steering Helm is a gearbox arrangement mounted on the dashboard of the boat. The Steering Wheel is mounted on the Shaft of the Helm. The Planetary Gear design uses three or more gears meshed internally which rotate on their own axis and also around the Central Helm Axis. This design ensures uniform distribution of the torque, thereby ensuring longer life of the Steering System with Higher Efficiency and Lower Feedback.

2. Steering Cable: SC-16-XX

The Steering Cable is a push pull Mechanical Cable which converts the rotary motion of the Helm to linear motion at the Engine / Rudder. One end of the cable is connected to the Helm & the other end to the Rudder.

3. Bezel Kit: B1B / B1W

Bezel Kit is a plastic part along with related hardware which is mounted between the Steering Wheel and dash board to cover the Helm hardware.

1.2 TECHNICAL SPECIFICATIONS

HELM - H1

Model No.	No. of Steering Wheel Turns	Maximum Steering Wheel Diameter	Shaft Length	Maximum Travel	Minimum Bend Radius	Maximum Working Load at Tiller End
H1	4 Appx.	16 inch (406 mm)	127.5 mm	9 inch (228 mm)	8 inch (203 mm)	5000N (500 Kg)

1.3 PRODUCT DIMENSIONS

MECHANICAL HELM PUMP : H1

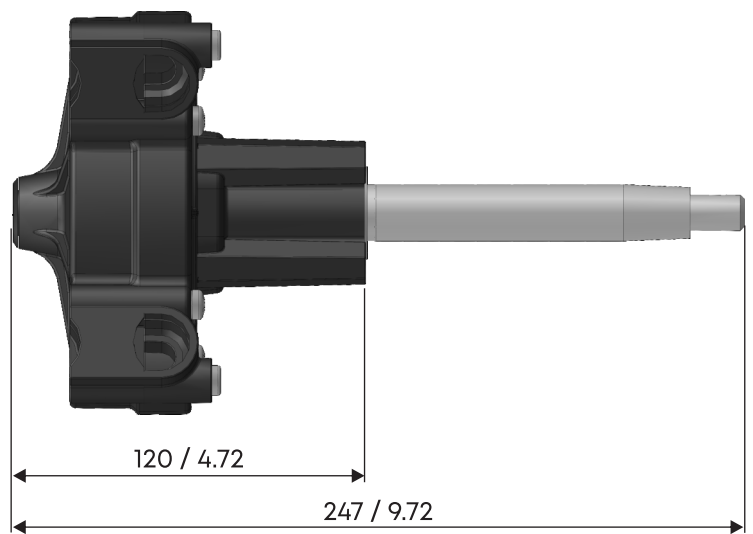
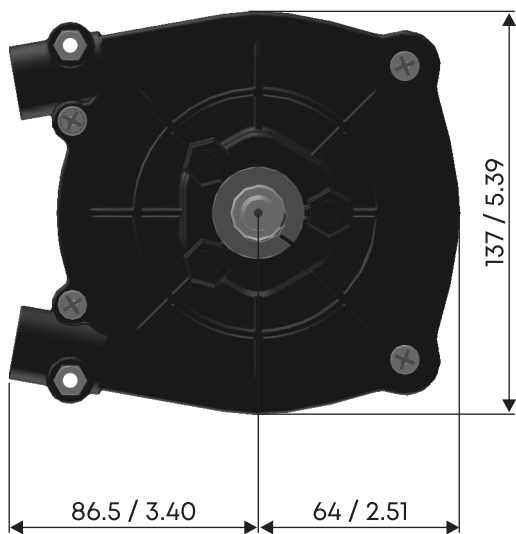

All Dimensions are in mm / Inch

1.4 PRODUCT EXPLODED VIEW

MECHANICAL STEERING SYSTEM : MS1

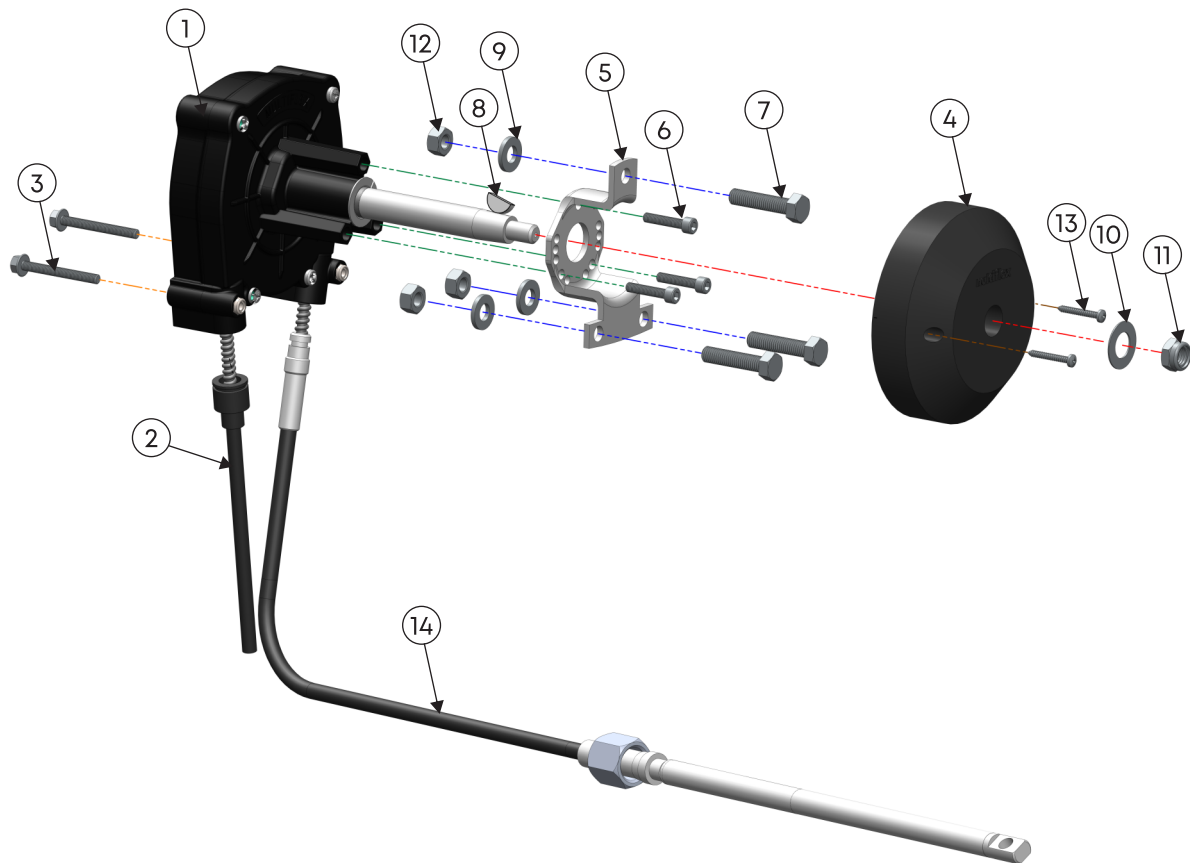

Item No.	Description	Qty.
1	Helm	01
2	Spent Tube / Plastic Sleeve	01
3	Flange Bolt	02
4	Plastic Bezel Cup	01
5	Mounting Bracket	01
6	M8 x 20 Bolt	03
7	Hex Bolt M8 x 45	03
8	Wood Ruff Key	01
9	Washer M8	03
10	Washer M12	01
11	Nyloc Nut M12 x 1.75	01
12	Nyloc Nut M8	03
13	ABS Screw	02
14	Steering Cable	01

SECTION 2 - PACKAGING CONTENT

2.1 GUIDELINE FOR PRODUCT HANDLING

Multiflex Mechanical Steering Kit MS1-XX:

The Net & Gross Weight of Multiflex Mechanical Steering Kit MS1-06 (6 Feet) is 5.85 kg (12.89 pounds) & 7.95 kg (17.52 pounds) and same for MS1-40 Feet is 12.65 Kg (27.88 pounds) & 14.75 kg (32.51 pounds). Thus, the Kit can be handled manually.

Multiflex Mechanical Helm - H1:

The Net & Gross Weight of Multiflex Mechanical Helm - H1 is 2.09 kg (4.60 pounds) & 2.28 kg (5.02 pounds). Thus, the Helm can be handled manually.

Multiflex Mechanical Steering Cable SC-16-XX:

The Net & Gross Weight of Multiflex Mechanical Steering Cable SC-16-06 (6 Feet) is 1.2 kg (2.64 pounds) & 1.57 Kg (3.46 pounds) and same for SC-16-40 (40 Feet) is 8 Kg (17.63 pounds) & 8.37 kg (18.45 pounds). Thus, the Steering Cable can be handled manually.

Multiflex Bezel Kit: B1B / B1W

The Net & Gross Weight of Multiflex Bezel Kit is 0.46 kg (1.01 pounds) & 0.50 kg (1.10 pounds). Thus, the Helm can be handled manually

CAUTION :

The staff handling the load must operate using all required PPE (individual protection devices) as required by the applicable standard on accident prevention at the workplace.

2.2 PACKING LIST

MECHANICAL STEERING SYSTEM (MS1-XX)

PACKAGING ITEMS

Model No.	Description	Qty.	Part No.
MECHANICAL STEERING KIT		01	MS1-XX
1	HELM	01	H1
A	SPENT TUBE / PLASTIC SLEEVE	01	SP-T1
B	FLANGE BOLT	02	FB-H1
C	MOUNTING TEMPLATE	01	MH1-MT
2	BEZEL KIT	01	B1B / B1W
A	PLASTIC BEZEL	01	BC-B1 / BC-W1
B	MOUNTING BRACKET	01	MB-H1
C	M8 X 20 BOLT	03	SH-H1
D	HEX BOLT M8 X 45	03	HB-H1
E	WOOD RUFF KEY	01	WK-H1
F	WASHER M8	03	WS1
G	WASHER M12	01	WS2
H	NYLOC NUT M12 X 1.75	01	H-NT1
I	NYLOC NUT M8	03	H-NT2
J	ABS SCREW	02	SC-B1
3	STEERING CABLE	01	SC-16-XX
4	INSTALLATION MANUAL	01	MS1-IM
5	DECLARATION OF CONFORMITY : HELM	01	H1-DC
6	DECLARATION OF CONFORMITY : STEERING CABLE	01	SC-16-DC

NOTE : Please ensure all the above components are in the package in a proper condition. In case of any missing components or damage, please contact the Seller for Warranty Claim.

CAUTION :

The packaging waste must be disposed properly according to the existing laws.

SECTION 3 - PRODUCT INSTALLATION

3.1 TOOLS REQUIRED DURING INSTALLATION

The following are the necessary tools required for the proper installation of the Multiflex Mechanical Steering System MS1-XX.

3" (77mm), 3 1/4" (82 mm) diameter
Hole Saw or Key Hole Saw



7/16", 9/16", 1/2" Box or Open Type
Wrench / Spanner



Torque
Wrench



9, 12, 13, 14, 16, 17 mm Wrench /
Spanner, Box or Open End type



3mm (1/8") Allen
Key / Wrench



Marine
Grease



Hand Drilling
Machine



5/16" (8mm) and 1/4" (7mm) dia.
Drill Bit



3.2 INSTALLING MECHANICAL HELM - H1

Step 1: Choose a suitable position to install the Steering Helm. Confirm if there is adequate space to move the Steering Wheel on the front side and sufficient space for the Helm with the Bezel Bracket and Steering Cable assembled on the back side of dashboard.

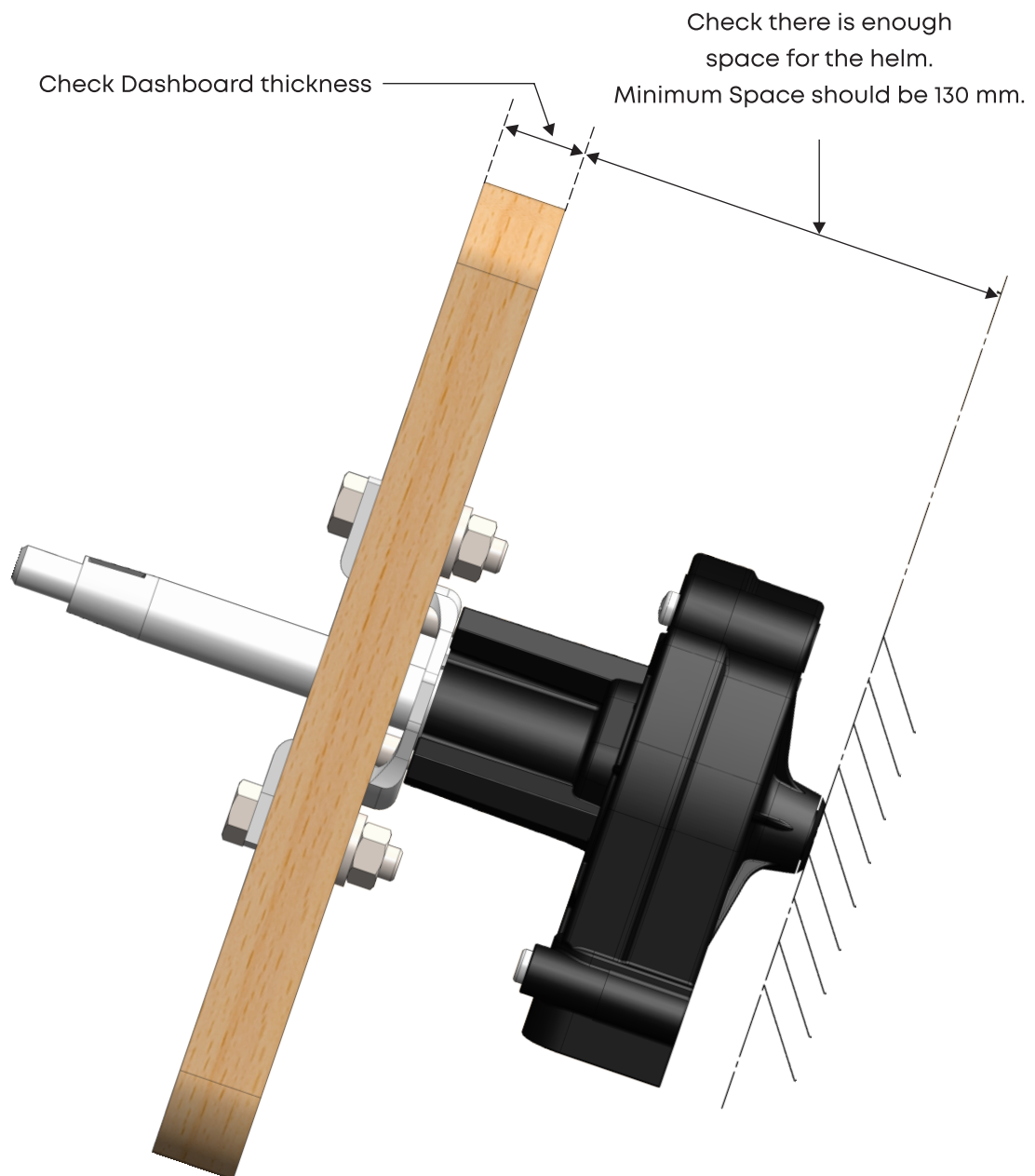

⚠ WARNING : **👷 SKILLED LABOR REQUIRED :**

For proper fastening of the Helm, the thickness of the dashboard must be minimum 12.7 mm (0.5") and maximum 54mm (2.1") thick. Thickness below or above these dimensions could lead to unsafe steering. After assembling the Helm, ensure that the 3 Nyloc Nuts (12) supplied are properly screwed on the Hex Bolts (7).

STEP 2 : Paste the Printed Bezel Bracket Mounting Template supplied with the Installation Manual on the dashboard at a suitable position where the Steering Helm is to be mounted with the help of tape.

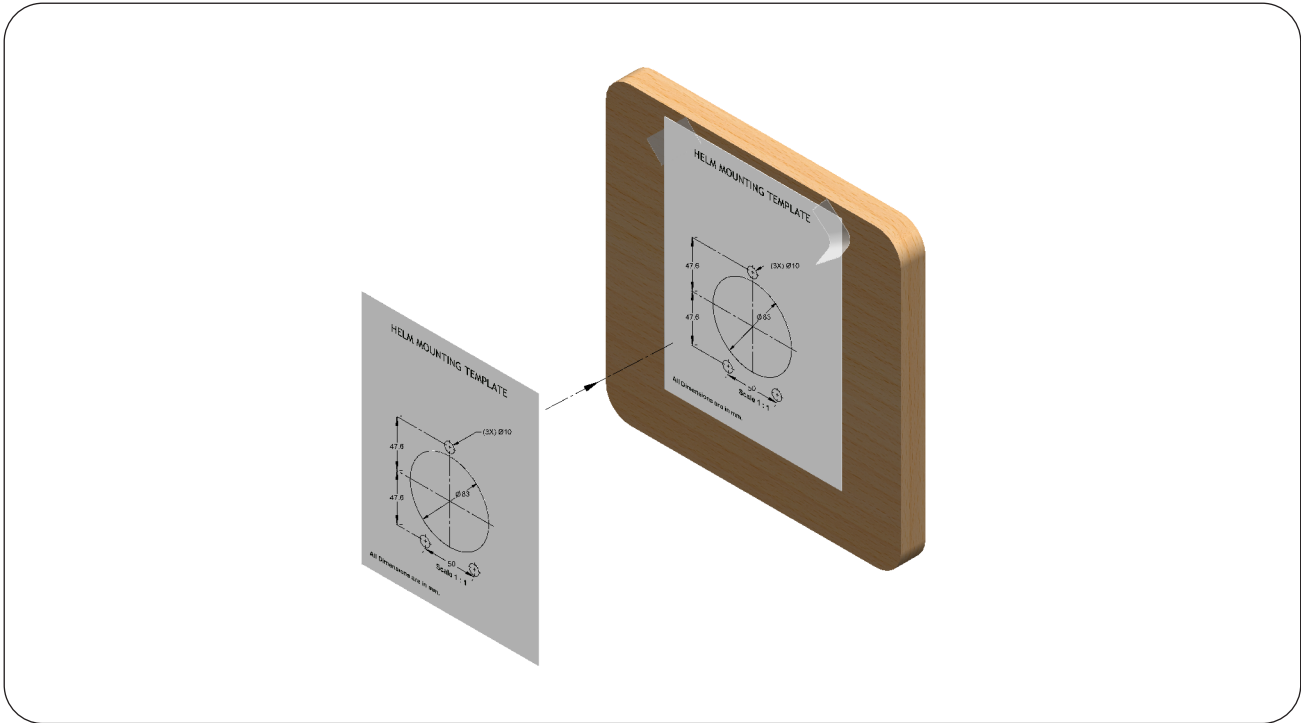

STEP 3 : Drill three small holes of diameter 10 mm (3/8") with the help of a Hand Drill & one big hole of diameter 83 mm (3-1/4") with the help of Hole Saw in the center as per the template.

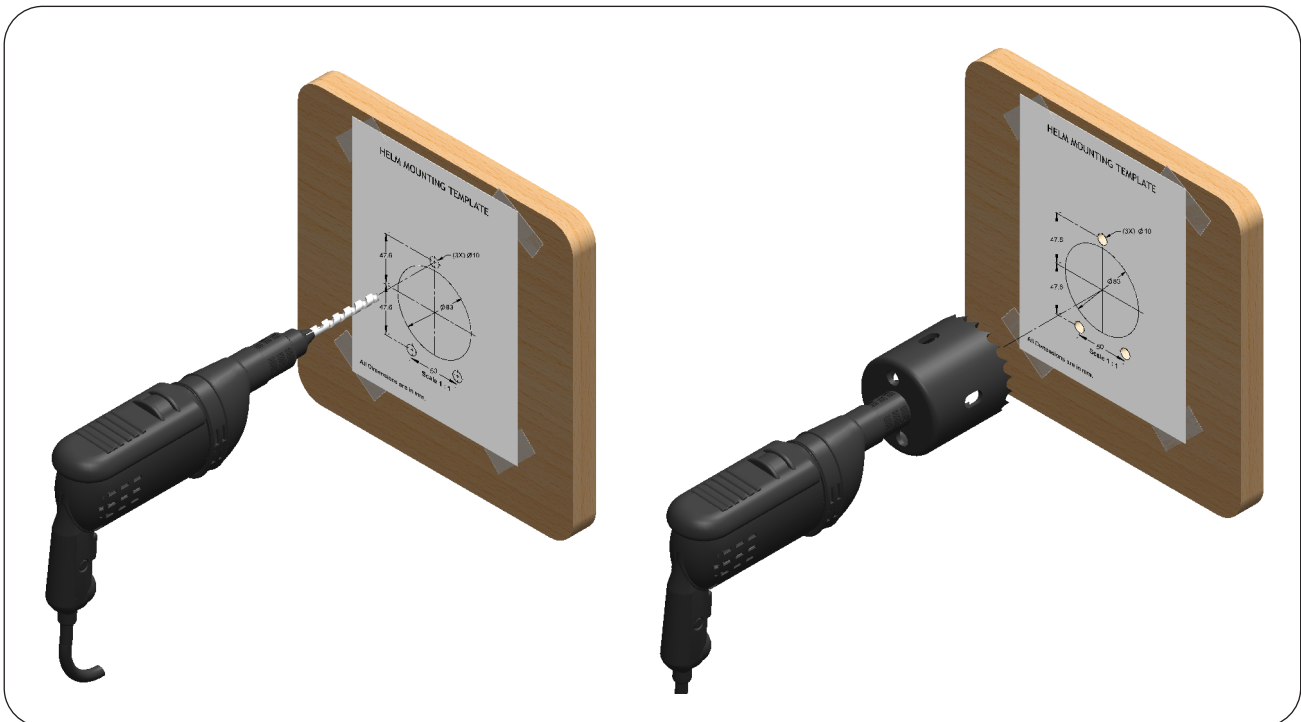

STEP 4: Place the Bezel Bracket (5) on the dashboard matching the 3 holes.

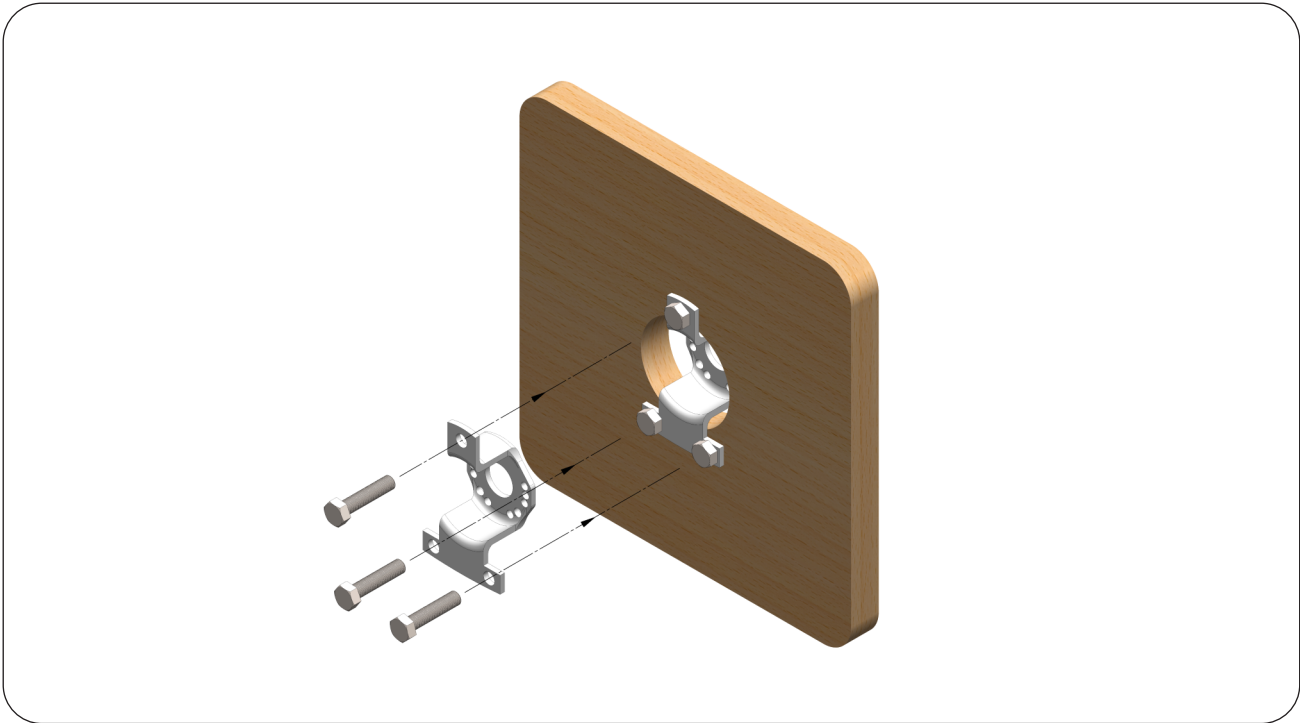

STEP 5: Tighten it using the Hex Bolts (7), Washers (9) and Nyloc Nuts (12) with the help of M8 Wrench at a torque of 15 Nm (11 lb ft).

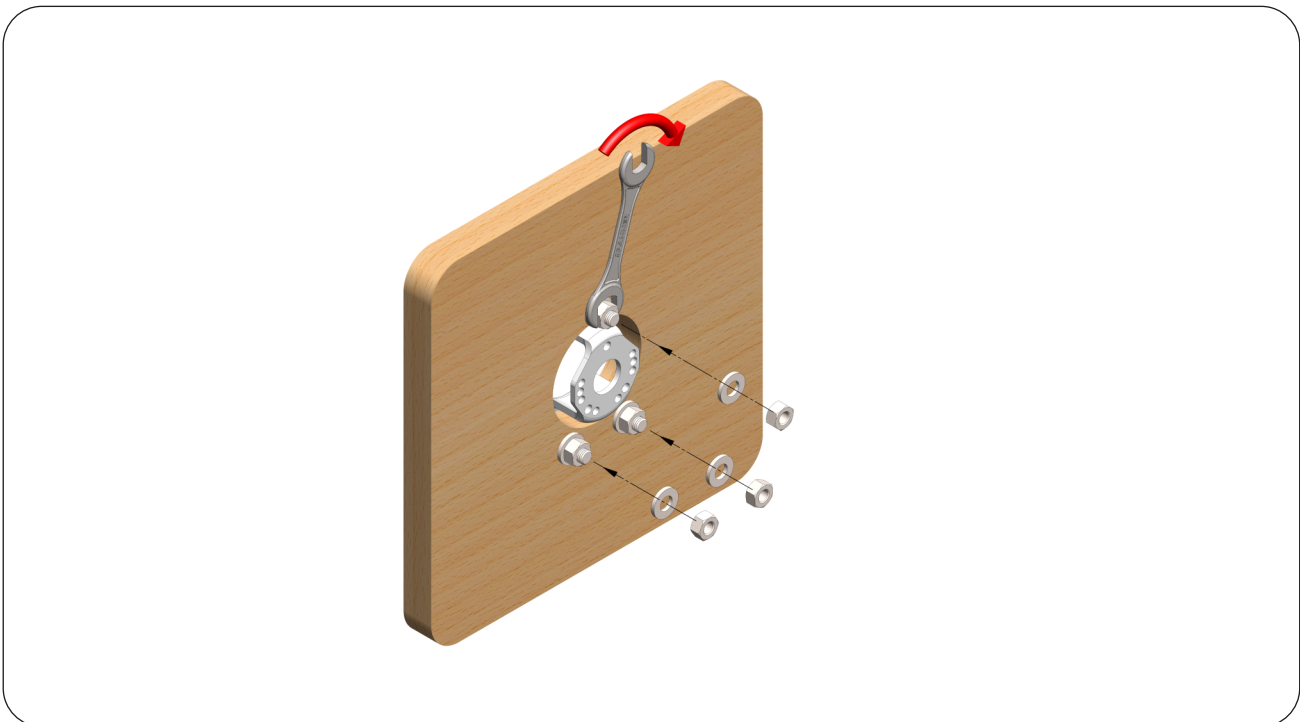

STEP 6 : Insert the Steering Helm Shaft (1) from the back side of dashboard through the center hole of Bezel Bracket (5) ensuring proper direction for entry of the Steering Cable. Place the Helm in the suitable position and align the three holes for mounting.

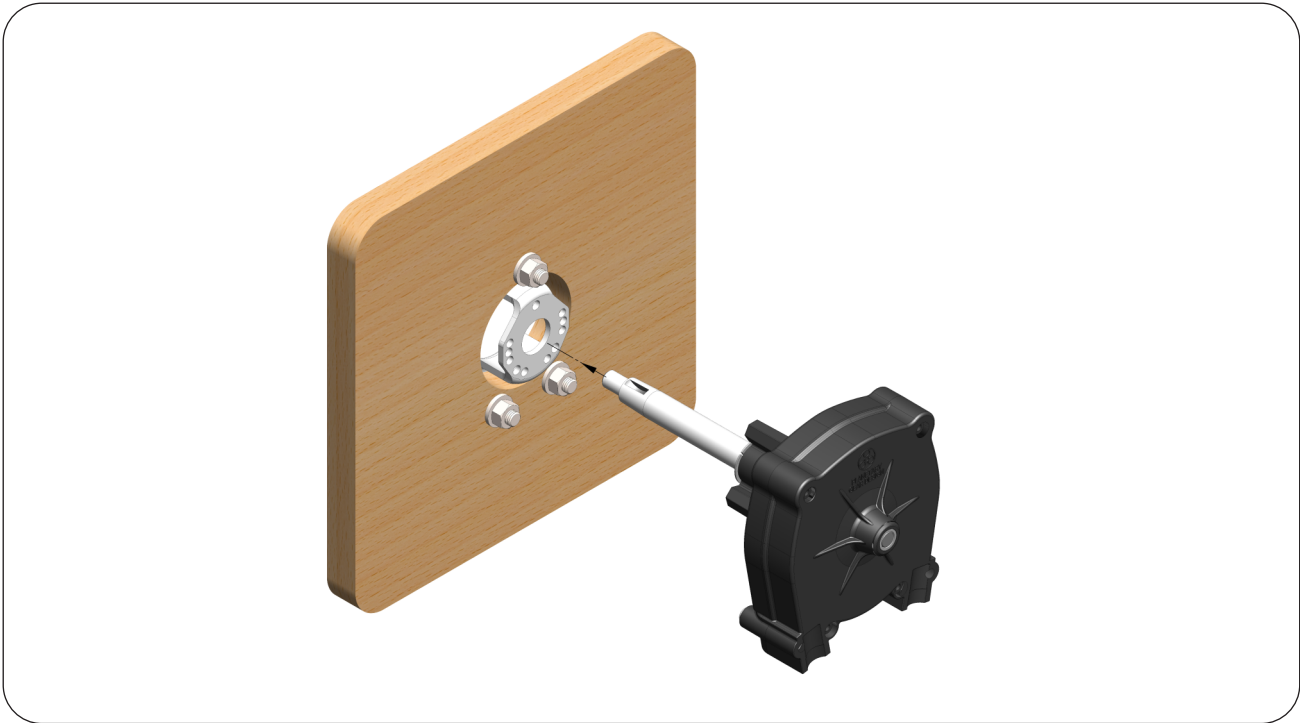

STEP 7 : The Helm can be mounted in 5 different positions (at every 45°). The correct position can be determined by the mounting side of the Steering Cable.



STEP 8: Tighten the Helm to the Bezel Bracket with three Allen Bolts (6) with torque of 25 Nm (18.5 lbft).

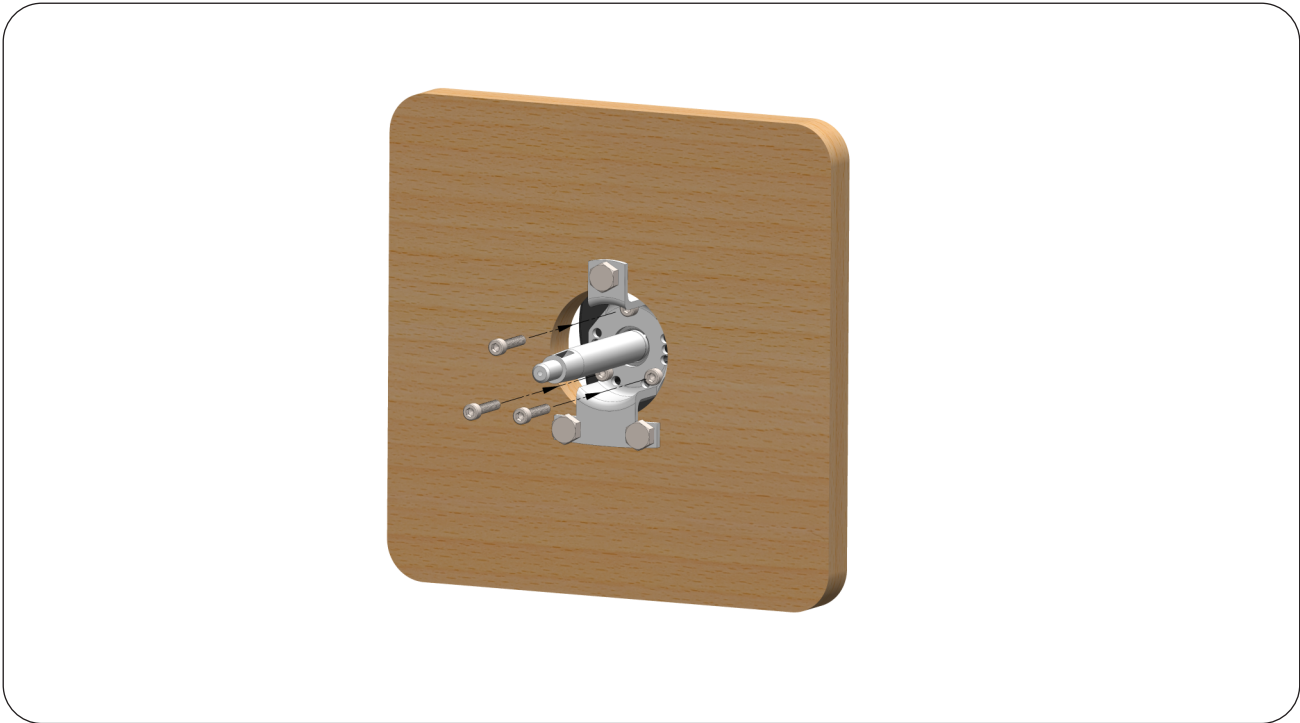

STEP 9: Insert the Bezel Cup (4) until it touches the dashboard. Fix the Bezel Cup (4) to the dashboard with two Self-Tapping Screws (13).

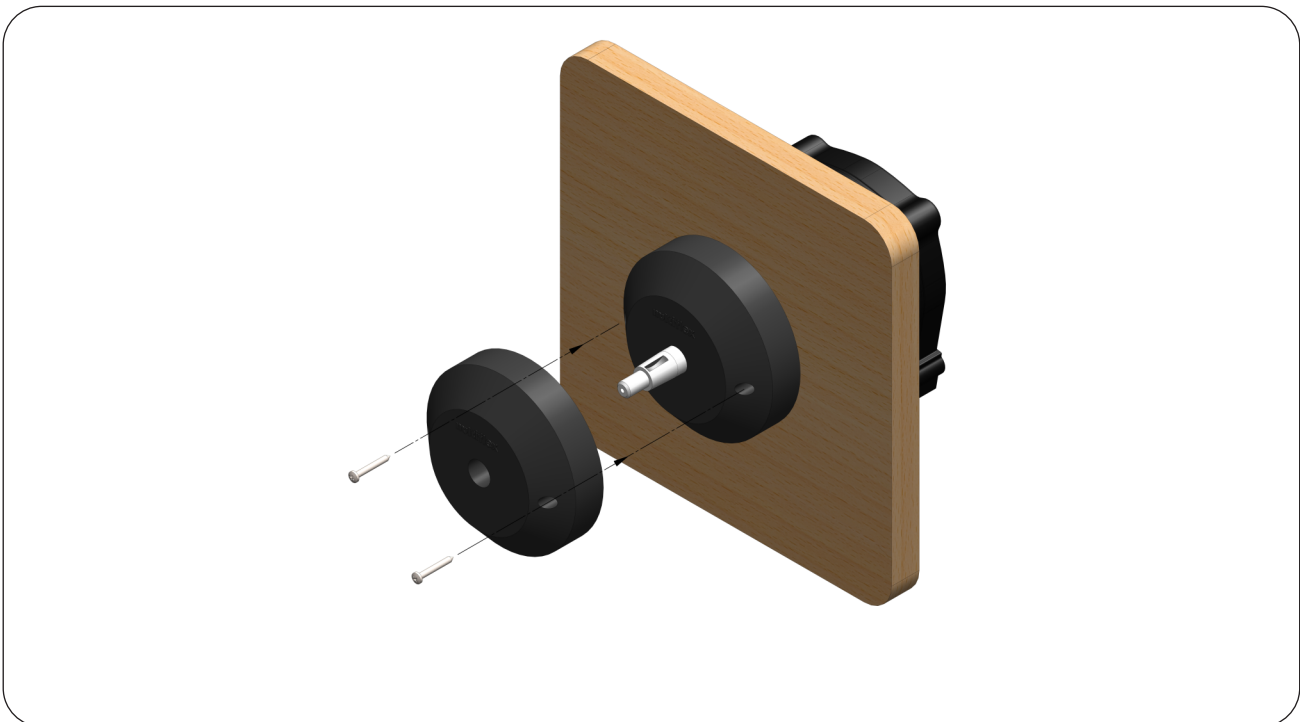

3.3 MOUNTING THE STEERING WHEEL



STEP 1: Apply grease lightly on the Tapered Shaft of the Helm. Slide the Steering Wheel supplied separately on the Helm Shaft.

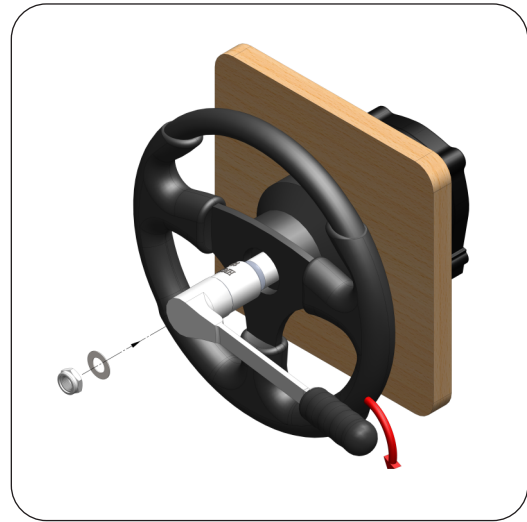

STEP 2 : Fit the Steering Wheel on the Shaft by inserting the Woodruff Key (8) in the key way. Insert the Washer (10) and use a 20mm Hexagonal Wrench to tighten the Nyloc Nut (11) with torque of 35 Nm (25.8 lb ft).



STEP 3: Fix the Wheel Cap at the center of the Wheel where cap slot is provided.

⚠ CAUTION :

Tighten the Steering Wheel Shaft Nyloc Nut (11) before Steering Cable Connection. Tighten Nyloc Nut (11) to 17 Nm (150 in.lb.). Do not exceed 22 Nm (200 in.lb.). If the Self-Locking Nut is removed, it must be replaced with new Self-Locking Nyloc Nut and not used one.

3.4 STEERING CABLE CONNECTION TO THE HELM

⚠ SKILLED LABOR REQUIRED :

STEP 1 : Determine the correct entry position of the Steering Cable into the Helm according to the proper Steering System.

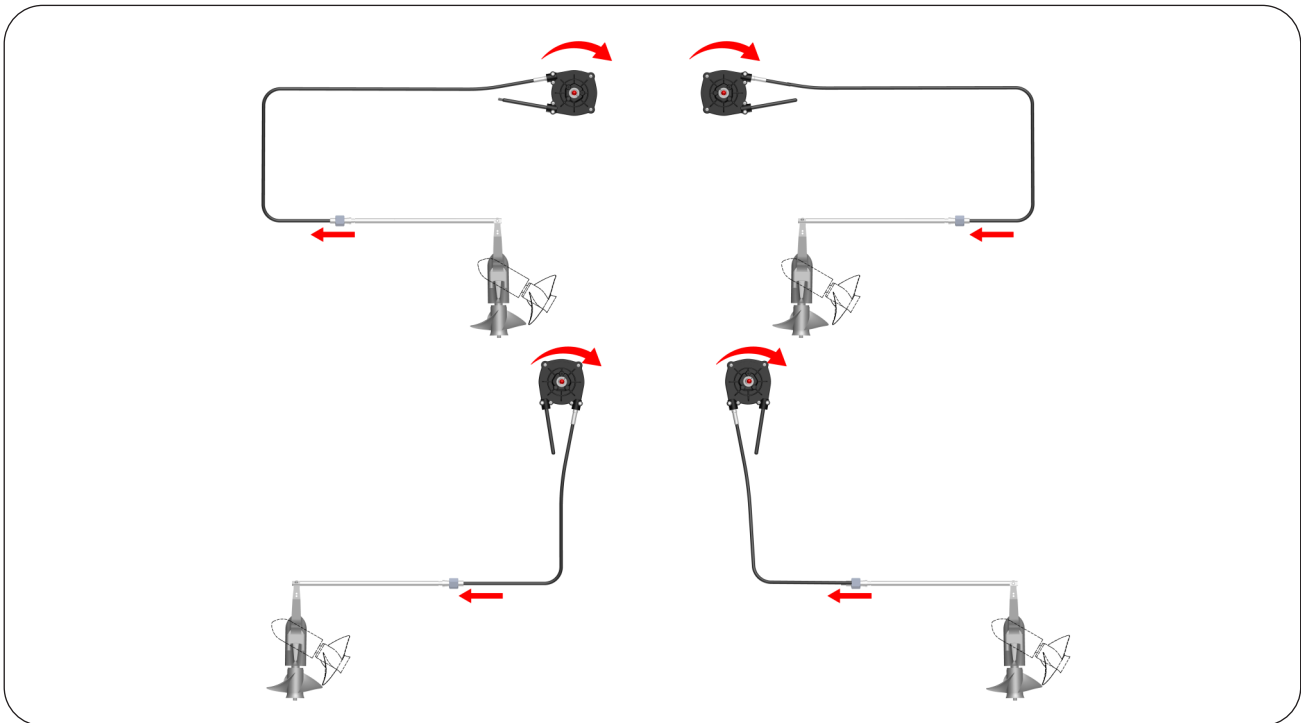

STEP 2 : Remove protective tube from Steering Cable and insert the loose end of helical inner (Steering Cable) into the Helm till it has meshed with the internal gear of Helm properly.

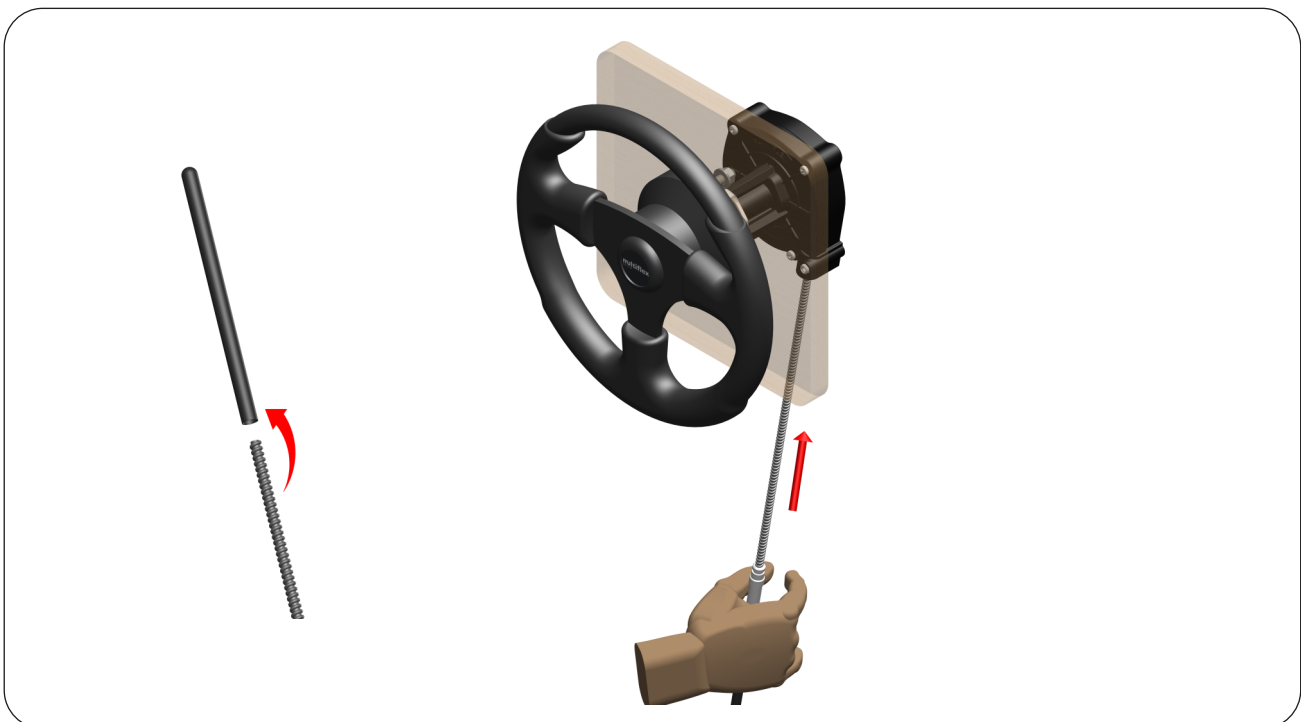

STEP 3 : Now rotate the Steering Wheel Counter Clockwise so as to draw the Cable fully into the Helm aligning the End Fitting Groove with Screw Hole. Lock the End Fitting of Cable with Flange Bolt (3) at torque of 6 Nm (4.4 lb ft).

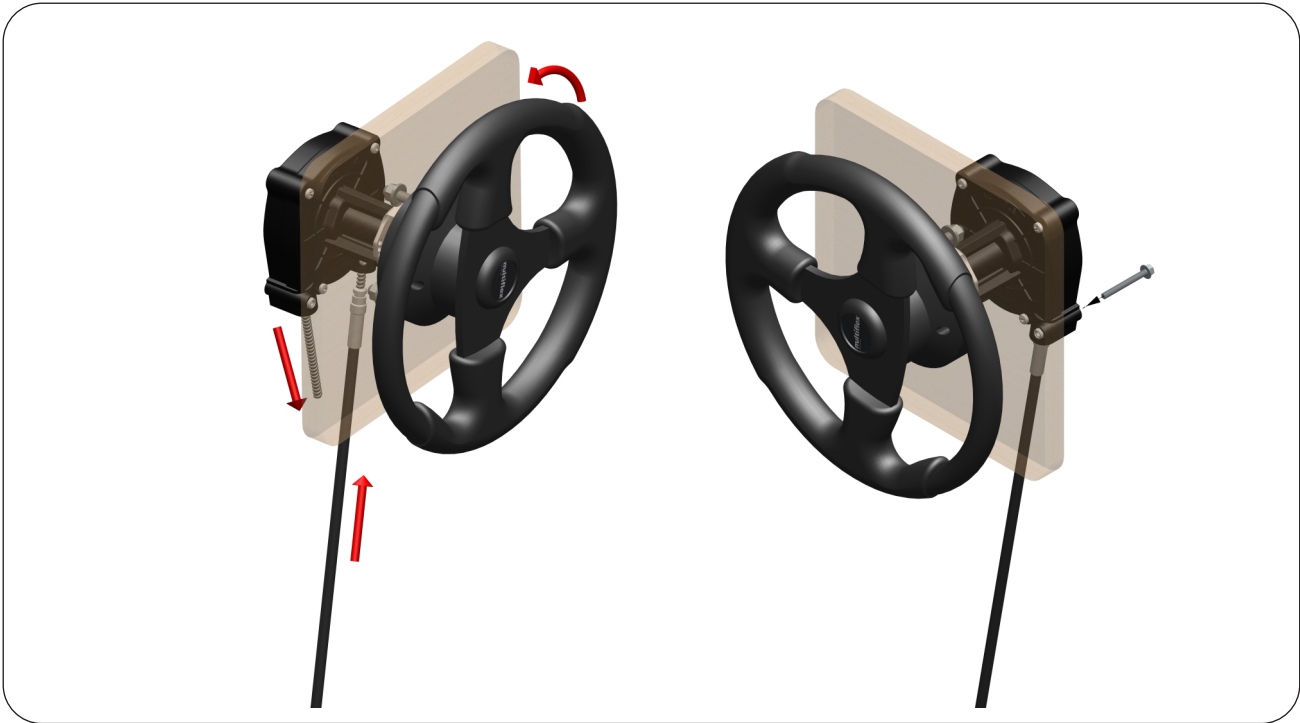

STEP 4 : Cover the loose exposed end of the Helical Inner (Steering Cable) with the Plastic Sleeve (2) by aligning to Groove with Screw Hole. Lock the Plastic Sleeves (2) with Flange Bolt (3) at torque of 6 Nm (4.4 lb ft).

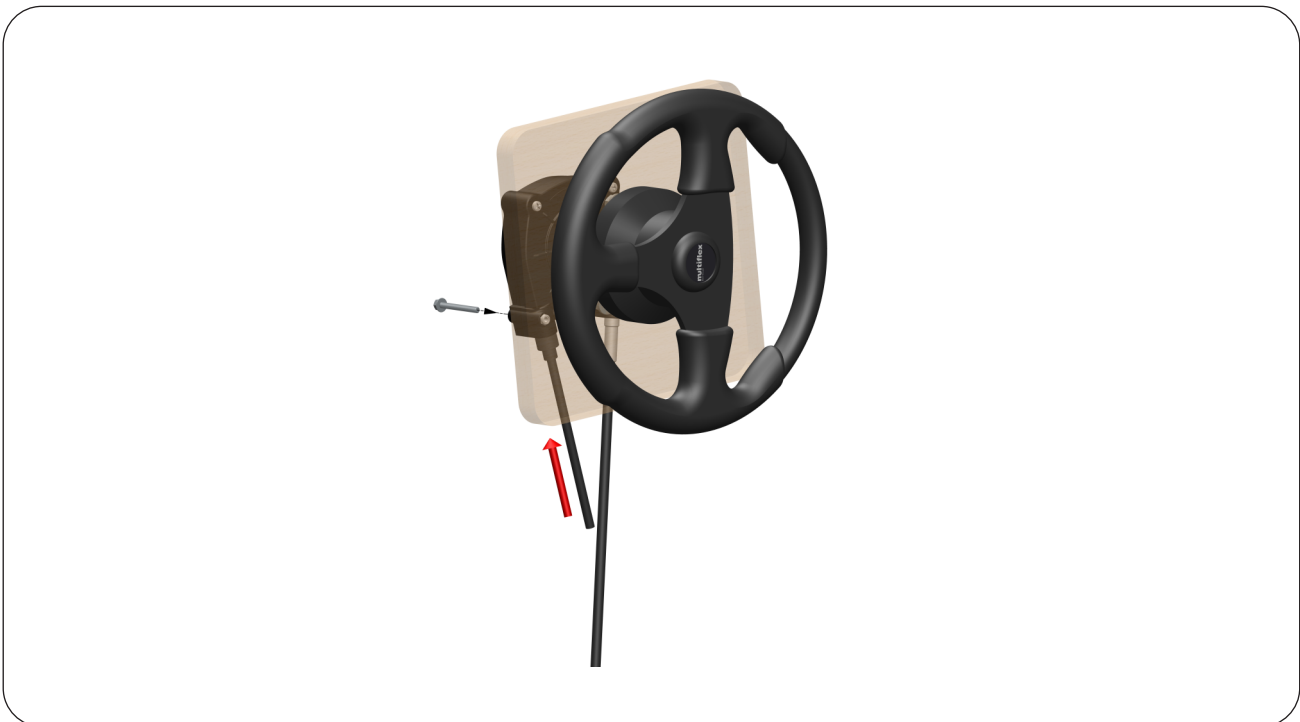

STEP 5: Fix the Steering Cable every 2 m (6 Ft.). The Cable must not be fixed to the electric wires.

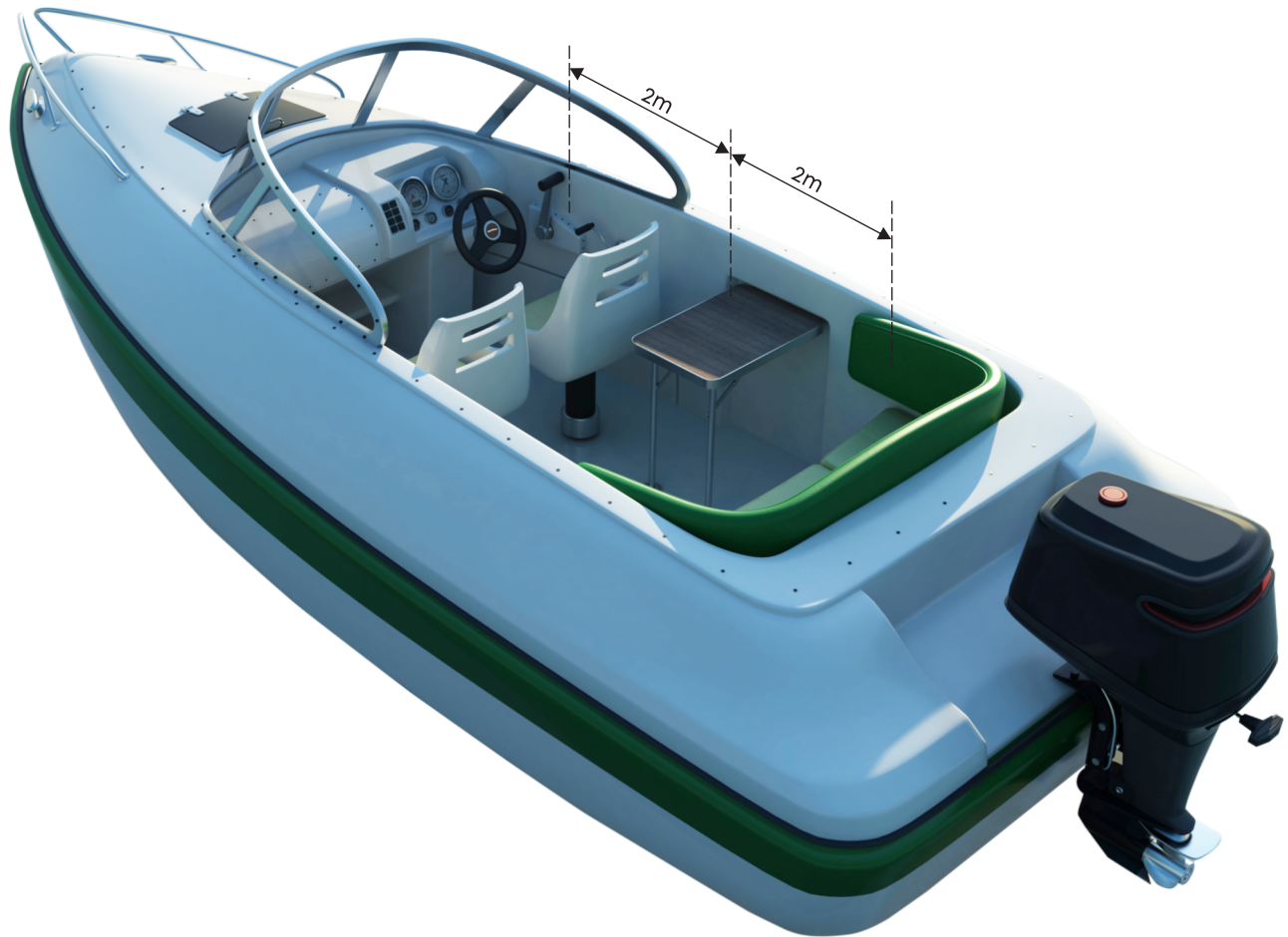

⚠ CAUTION :

Rotate the Steering Wheel to Clockwise & Anticlockwise to verify the direction of the Steering Wheel rotation corresponds to the boat direction.

3.5 VERIFICATION OF STEERING SYSTEM

Check the system installation by rotating the steering wheel. Clockwise rotation should move to starboard and anti-Clockwise rotation should move to the port. The cable movement direction should correspond as per the figure.

Check the entire Steering System after first two hours of running for loose bolts, nuts, and fasteners.

 **DANGER :**

- ✦ Do not let any dust or foreign particle come in contact with the cable end, to prevent machinery damages.
- ✦ If conduit comes in contact with cutting edges, it may be damaged.
- ✦ This control must be carried out before the boat is operated in water.

SECTION 4 – TROUBLESHOOTING

4.1 DISASSEMBLING

For any reason, if the system has to be removed, it is very important to dispose the waste properly considering the environment.

It is requested to return this product to a nearby registered dismantler or recycler while disposing this product.

4.2 DISMANTLING STEERING WHEEL

SW-PL

Use a specific dismantling tool to remove the Steering Wheel from the Helm Shaft.



CAUTION :

Never use a hammer or other hammering tools that could cause irreparable damage to the Helm or Helm components.

SECTION 5 – MAINTENANCE

5.1 MAINTENANCE WARNING

Poor installation and maintenance may result in loss of steering and cause property damage and/or personal injury. Maintenance requirements change according to climate, frequency and the use. Inspections are necessary at least every two years and must be carried out by specialized marine technicians.

Carry out the following maintenance operations :

- ✦ Periodically wash with water and soap the components removing any salt deposit.
- ✦ Every month check and if necessary tighten all the nuts fastening the system.

WARNING

Release or separation of one of the fasteners can cause failure of steering system resulting in property damage, injury or death.

- ✦ Periodically check the absence of corrosion on the metal parts of the cable end fittings and of abrasions on the conduit.
- ✦ Replace the damaged parts that could compromise the steering system integrity.

PREVENTIVE MAINTENANCE

Steering system should be serviced every 30 days when in sea water and every 90 days when in fresh water.

- ✦ Check all metal parts for corrosion.
- ✦ Check the cable for damaged conduit.
- ✦ Check for loose bolts, nuts & fasteners.

5.2 ROUTINE MAINTENANCE

Multiflex Steering System if properly installed and maintained, gives you years of safe and reliable performance.

 **WARNING :**  **SKILLED LABOR REQUIRED :**

Poor installation and maintenance may result in loss of Steering and cause property damage and / or personal injury. Maintenance requirements change according to climate, frequency and the use. Inspections are necessary at least every two years and must be carried out by specialized marine technicians. Carry out the following maintenance operations:

- ✦ Periodically wash with water and soap the components removing any salt deposit.
- ✦ Every month check and if necessary tighten all the nuts fastening the system.

 **DANGER :**

Release or separation of one of the fasteners can cause failure of Steering System resulting in property damage, injury or death.

- ✦ Periodically check the absence of corrosion on the metal parts of the cable end fittings and of abrasions on the conduit.
- ✦ Replace the damaged parts that could compromise the Steering System integrity.

UPGRADE TO **multisteer** HYDRAULIC STEERING SYSTEM



Hydraulic Steering System
for Engines up to 115 Hp : OH-115



Hydraulic Steering System
for Engines up to 175 Hp : OH-175



Hydraulic Steering System
for Engines up to 250 Hp : OH-250



Hydraulic Steering System
for Engines up to 350 Hp : OH-350



Hydraulic Side Mount Steering System
for Engines up to 300 Hp : SH-300

multiflex
BUILT TO LAST

+91 9175900574 | technical@multiflexmarine.com | www.multiflexmarine.com

©2020 | Multiflex Marine | All Rights Reserved